

Boeing 767 Freighter

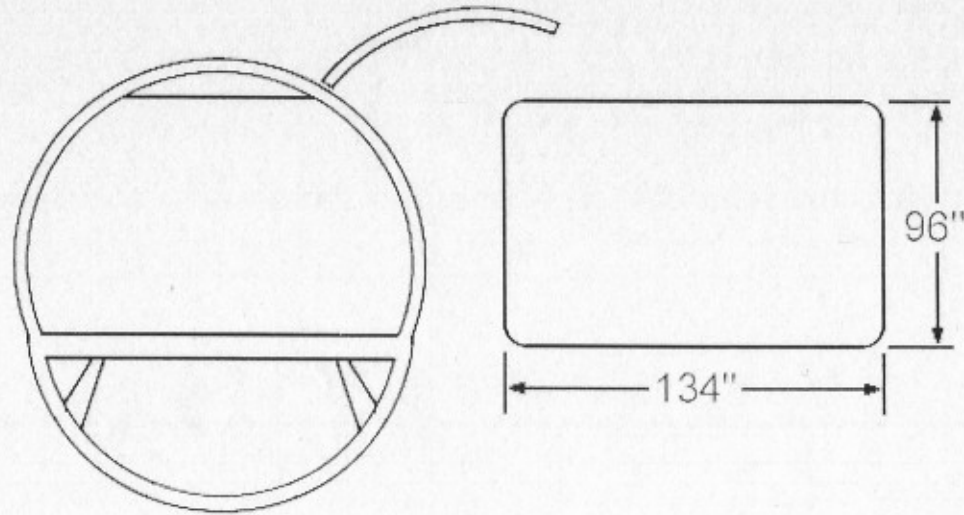

Package Height (Inches)	Package Width (Inches)																					
	6	12	18	24	30	36	42	48	54	60	66	72	78	84	90	96	102	108	114	120	126	132
6 to 42	1109	1046	878	728	623	544	484	435	396	363	335	312	292	274	258	244	232	219	208	197	188	179
48	1109	1016	823	690	594	522	466	421	384	353	327	304	285	268	253	240	228	215	204	194	184	176
54	1089	930	762	646	561	496	445	403	369	340	316	295	277	261	247	234	222	210	199	189	180	172
60	1037	834	695	597	523	466	420	383	352	326	303	284	267	252	239	227	215	203	192	183	174	166
66	902	740	628	546	483	433	393	360	333	309	289	271	256	243	231	219	206	195	184	175	167	159
72	773	650	561	494	442	400	365	337	312	292	274	258	244	232	221	208	196	185	175	166	158	151
78	658	566	497	443	400	365	336	312	291	273	257	243	231	220	208	195	183	173	164	156	148	142
84	551	484	432	391	357	329	305	284	267	252	238	227	216	204	190	179	168	159	150	143	136	
90	460	412	373	342	315	293	274	257	243	230	219	209	196	182	170	160	150	142	134			
96	374	341	314	291	271	255	240	227	216	207	196	179	165	154	143	134						

